

# Strut Clamp – ZSCE

## EMT Strut Clamp

Standard finish is Electro-Galvanized (EG).

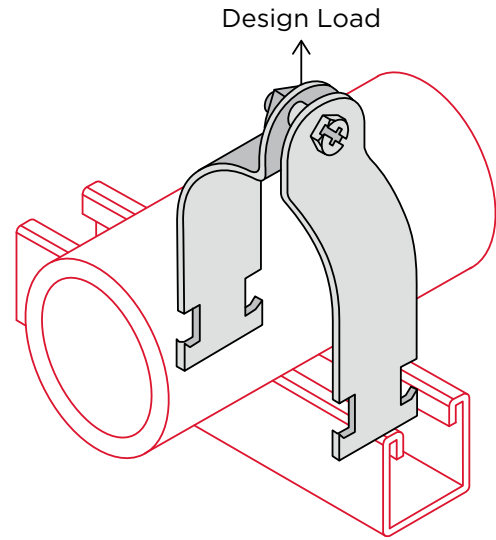

CATALOG NUMBER	EMT SIZE		OD		DESIGN LOAD		WEIGHT
	in.	mm	in.	mm	lbs.	kN	lbs.
<b>ZSCE0050EG</b>	½	15	0.706	17.9	400	1.78	0.10
<b>ZSCE0075EG</b>	¾	20	0.922	23.4	400	1.78	0.11
<b>ZSCE0100EG</b>	1	25	1.163	29.5	600	2.67	0.14
<b>ZSCE0125EG</b>	1¼	32	1.510	38.4	600	2.67	0.16
<b>ZSCE0150EG</b>	1½	40	1.740	44.2	800	3.56	0.26
<b>ZSCE0200EG</b>	2	50	2.197	55.8	800	3.56	0.32

### Material Specifications and Finishes

Carbon Steel – ASTM A1011-00 SS GR 33 or ASTM A1011-00CS Type B

EG – Electro-Galvanized. Electroplating deposits zinc on the surface of the steel by electrolysis from a bath of zinc salts. Recommended for relatively dry indoor use. This is the standard coating for most ZI-Strut products. Thickness of applied zinc is between 0.2 mils and 0.5 mils (5.1 µm to 12.7 µm). Coatings on ZI-Strut EG products meet ASTM B633 SC1 Type III.

HD – Hot Dip Galvanized After Fabrication. Fabricated product is dipped in molten zinc and is completely covered on all surfaces. Recommended for outdoor use. Coatings on ZI-Strut HD products meet ASTM A123/153. The zinc coating is typically 2.6 mils (66.0 µm) or 1.5 oz. per square foot (0.46 kg per square meter) per side.

S4 – 304 Stainless Steel – ASTM A240 (Type 304)

S6 – 316 Stainless Steel – ASTM A240 (Type 316)  
316 Stainless Steel Nuts – ASTM A276-03

YC – Yellow Zinc Dichromate. A 0.5 mil (12.7 µm) electro-galvanized zinc plating meeting ASTM B633 SC1 Type III is applied to the surface of the metal. Yellow Dichromate is applied over the zinc. This results in a yellowish gold appearance and acts as a nonporous barrier sealant that is corrosion resistant and can be painted.

Note: Specifications subject to change without notice.

## SUBMITTAL INFORMATION

PROJECT: \_\_\_\_\_ CONTRACTOR: \_\_\_\_\_ DATE: \_\_\_\_\_

ENGINEER: \_\_\_\_\_ SPECIFICATION REFERENCE: \_\_\_\_\_ SYSTEM TYPE: \_\_\_\_\_

LOCATIONS: \_\_\_\_\_ COMMENTS: \_\_\_\_\_

ZI-112823