

Roller — ZR23

Pipe Roller Heavy Duty 16-24" Pipe

Standard finish is Electro-Galvanized (EG).

Max load rating of 2000 lbs. (8.90 kN) with 12 ga. channel.

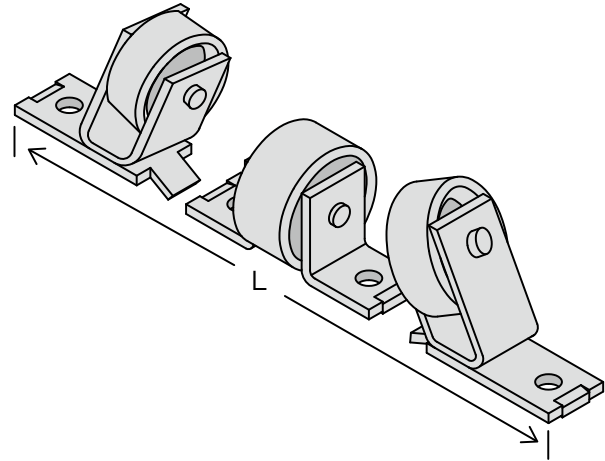

CATALOG NUMBER	WEIGHT
	lbs.
ZR230000EG	14.72

Material Specifications and Finishes

Carbon Steel — ASTM A1011-00 SS GR 33 or ASTM A1011-00CS Type B

EG — Electro-Galvanized. Electroplating deposits zinc on the surface of the steel by electrolysis from a bath of zinc salts. Recommended for relatively dry indoor use. This is the standard coating for most ZI-Strut products. Thickness of applied zinc is between 0.2 mils and 0.5 mils (5.1 μ m to 12.7 μ m). Coatings on ZI-Strut EG products meet ASTM B633 SC1 Type III.

Note: Specifications subject to change without notice.

SUBMITTAL INFORMATION

PROJECT: _____ CONTRACTOR: _____ DATE: _____

ENGINEER: _____ SPECIFICATION REFERENCE: _____ SYSTEM TYPE: _____

LOCATIONS: _____ COMMENTS: _____

ZI-120523

Roller — ZR23

PIPE SIZE	PIPE COVERING THICKNESS		ACTUAL OD OF PIPE + SHIELD + INSULATION		DIMENSION L		DIMENSION CL	
	in.	mm	in.	mm	in.	mm	in.	mm
16	0	0.0	16	406.4	12 ³ / ₄	323.9	11 ³ / ₈	288.9
	1 ¹ / ₂	38.1	19 ⁵ / ₈	498.5				
	2	50.8	20 ³ / ₈	517.5				
	2 ¹ / ₂	63.5	21 ⁵ / ₈	549.3				
	3	76.2	22 ¹ / ₈	562.0				
	4	101.6	24 ³ / ₈	619.1				
18	0	0.0	18	457.2	12 ³ / ₄	323.9	12 ¹ / ₄	311.2
	1 ¹ / ₂	38.1	21 ⁵ / ₈	549.3				
	2	50.8	22 ⁵ / ₈	574.7				
	2 ¹ / ₂	63.5	23 ¹ / ₄	590.6				
	3	76.2	24 ¹ / ₄	616.0				
	4	101.6	26 ⁵ / ₈	676.3				
20	0	0.0	20	508.0	14 ¹ / ₈	358.8	13 ¹ / ₄	336.6
	1 ¹ / ₂	38.1	23 ¹ / ₄	590.6				
	2	50.8	24 ¹ / ₂	622.3				
	2 ¹ / ₂	63.5	25 ¹ / ₂	647.7				
	3	76.2	26 ⁵ / ₈	676.3				
	4	101.6	28 ¹ / ₄	717.6				
24	0	0.0	24	609.6	14 ¹³ / ₁₆	376.2	15 ¹ / ₄	387.4
	1 ¹ / ₂	38.1	27	685.8				
	2	50.8	28	711.2				
	2 ¹ / ₂	63.5	29 ¹ / ₄	743.0				
	3	76.2	30 ¹ / ₂	774.7				
	4	101.6	32 ¹ / ₈	835.0				
30	0	0.0	30	762.0	15 ⁷ / ₈	403.2	16 ¹ / ₄	412.8

