

Concrete Insert – ZCIN

Concrete Insert Nut

Standard finishes are Electro-Galvanized (EG) and Plain (PL).

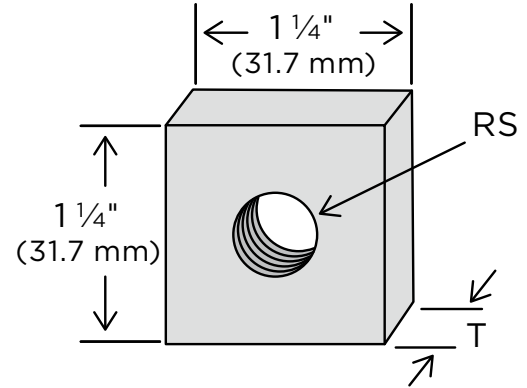

CATALOG NUMBER		WT	RS	T (THICKNESS)
PLAIN FINISH	EG FINISH	lbs.		in.
ZCIN0025PL	ZCIN0025EG	0.11	1/4"-20	1/4
ZCIN0037PL	ZCIN0037EG	0.16	3/8"-16	1/4
ZCIN0050PL	ZCIN0050EG	0.20	1/2"-13	5/16
ZCIN0062PL	ZCIN0062EG	0.18	5/8"-11	5/16
ZCIN0075PL	ZCIN0075EG	0.17	3/4"-10	1/2
ZCIN0087PL	ZCIN0087EG	0.15	7/8"-9	1/2

Material is 1 3/8" (41.3 mm) wide x 1/4" (6.3 mm) thick unless specified. Holes are 3/16" (4.8 mm) diameter, 13/16" (20.6 mm) center to edge on 1 7/8" (47.6 mm) centers unless specified.

Material Specifications and Finishes

Carbon Steel – ASTM A1011-00 SS GR 33 or ASTM A1011-00CS Type B

EG – Electro-Galvanized. Electroplating deposits zinc on the surface of the steel by electrolysis from a bath of zinc salts. Recommended for relatively dry indoor use. This is the standard coating for most ZI-Strut products. Thickness of applied zinc is between 0.2 mils and 0.5 mils (5.1 μm to 12.7 μm). Coatings on ZI-Strut EG products meet ASTM B633 SC1 Type III.

PL – Plain. No coating on the steel except some oil left on the part from the pickle and oil or fabrication process.

Note: Specifications subject to change without notice.

SUBMITTAL INFORMATION

PROJECT: _____ CONTRACTOR: _____ DATE: _____

ENGINEER: _____ SPECIFICATION REFERENCE: _____ SYSTEM TYPE: _____

LOCATIONS: _____ COMMENTS: _____

ZI-112823