

Beam Clamp – ZBC17

Formed Steel Heavy Duty Beam Clamp

Standard finish is Electro-Galvanized (EG).

For 3/4-1 5/8" (19-41 mm) flange thickness.

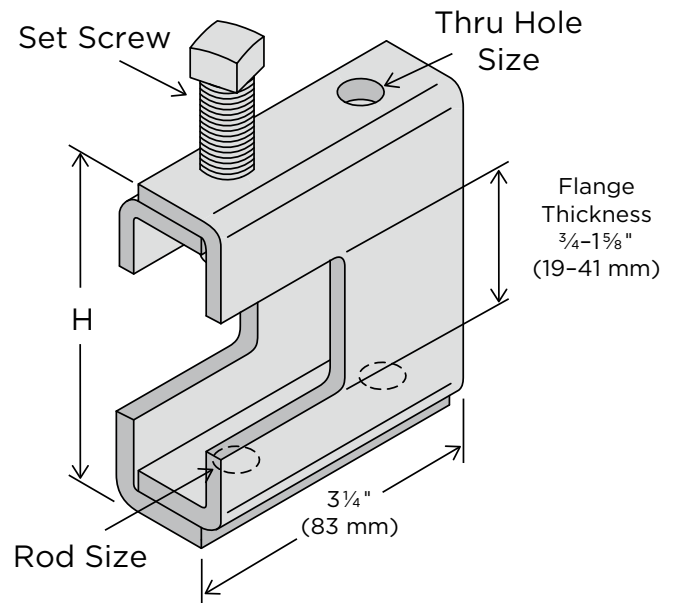

CATALOG NUMBER	WEIGHT	ROD SIZE	HOLE SIZE		H		SET SCREW	MATERIAL THICKNESS	DESIGN LOAD	
			in.	mm	in.	mm			lbs.	kN
ZBC170025EG	1.51	3/8	7/16	11.1	3 5/8	92	1/2"-13 x 2"	3/16	800	3.56
ZBC170037EG	1.51	3/8	7/16	11.1	3 5/8	92	1/2"-13 x 2"	3/16	800	3.56
ZBC170050EG	1.93	1/2	9/16	14.3	3 13/16	97	1/2"-13 x 2"	1/4	1300	5.78
ZBC170062EG	3.11	5/8	N/A	—	3 5/8	92	5/8"-11 x 2"	5/16	1900	8.45

Material Specifications and Finishes

Carbon Steel – ASTM A1011-00 SS GR 33 or ASTM A1011-00CS Type B

S4 – 304 Stainless Steel – ASTM A240 (Type 304)

S6 – 316 Stainless Steel – ASTM A240 (Type 316)

EG – Electro-Galvanized. Electroplating deposits zinc on the surface of the steel by electrolysis from a bath of zinc salts. Recommended for relatively dry indoor use. This is the standard coating for most ZI-Strut products. Thickness of applied zinc is between 0.2 mils and 0.5 mils (5.1 µm to 12.7 µm). Coatings on ZI-Strut EG products meet ASTM B633 SC1 Type III.

HD – Hot Dip Galvanized After Fabrication. Fabricated product is dipped in molten zinc and is completely covered on all surfaces. Recommended for outdoor use. Coatings on ZI-Strut HD products meet ASTM A123/153. The zinc coating is typically 2.6 mils (66.0 µm) or 1.5 oz. per square foot (0.46 kg per square meter) per side.

Note: Specifications subject to change without notice.

SUBMITTAL INFORMATION

PROJECT: _____ CONTRACTOR: _____ DATE: _____

ENGINEER: _____ SPECIFICATION REFERENCE: _____ SYSTEM TYPE: _____

LOCATIONS: _____ COMMENTS: _____

ZI-112823