

Roller — ZR21

Pipe Roller

Standard finish is Electro-Galvanized (EG).

Max load rating of 750 lbs. (3.34 kN) with 12 ga. channel.

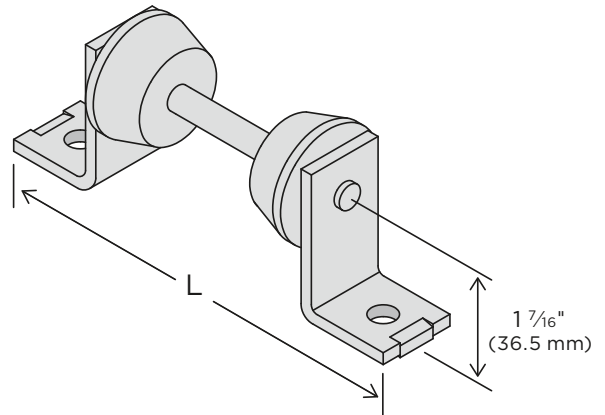

CATALOG NUMBER	WEIGHT		PIPE OD
	lbs.	in.	mm
ZR213740EG	2.66	3 ³ / ₄ -4	95-102
ZR214360EG	2.71	4 ³ / ₈ -6	111-152
ZR216380EG	2.75	6 ³ / ₈ -8	162-203
ZR219010EG	2.79	9-10	229-254

Material Specifications and Finishes

Carbon Steel — ASTM A1011-00 SS GR 33 or ASTM A1011-00CS Type B

EG — Electro-Galvanized. Electroplating deposits zinc on the surface of the steel by electrolysis from a bath of zinc salts. Recommended for relatively dry indoor use. This is the standard coating for most ZI-Strut products. Thickness of applied zinc is between 0.2 mils and 0.5 mils (5.1 µm to 12.7 µm). Coatings on ZI-Strut EG products meet ASTM B633 SC1 Type III.

Note: Specifications subject to change without notice.

SUBMITTAL INFORMATION

PROJECT: _____ CONTRACTOR: _____ DATE: _____

ENGINEER: _____ SPECIFICATION REFERENCE: _____ SYSTEM TYPE: _____

LOCATIONS: _____ COMMENTS: _____

WEL-111822

Roller — ZR21

PIPE SIZE	PIPE COVERING THICKNESS		ACTUAL OD OF PIPE + SHIELD + INSULATION		DIMENSION L		DIMENSION CL	
	in.	mm	in.	mm	in.	mm	in.	mm
3½	0	0.0	4	101.6	7¼	184.2	4¾	111.1
	1¼	31.8	6¾	168.3	9¼	235.0	5½	138.1
	1¾	46.0	7¾	187.3	9¼	235.0	5¾	147.6
	2¼	57.2	8¾	219.1	10⅞	257.2	6¾	161.9
	2¾	69.9	9¾	238.1	10⅞	257.2	6¾	171.5
	3⅝	84.1	10¾	273.1	10⅞	276.2	7¾	187.3
4	0	0.0	4½	114.3	8¼	209.6	4½	114.3
	1⅛	27.0	7¾	181.0	9¼	235.0	5½	144.5
	1½	39.7	8¾	206.4	10⅞	257.2	6½	154.0
	2⅛	52.4	9¾	231.8	10⅞	257.2	6¾	168.3
	2½	65.1	10	254.0	10⅞	257.2	7½	179.4
	3⅛	77.8	11¼	285.8	10⅞	276.2	7¾	193.7
	4⅛	103.2	13	330.2	10⅞	276.2	8¾	217.5
5	0	0.0	5¾	142.9	8¼	209.6	5½	128.6
	1	25.4	8¼	209.6	10⅞	257.2	6½	155.6
	1½	38.1	9¾	238.1	10⅞	257.2	6¾	171.5
	2	50.8	10¾	263.5	10⅞	276.2	7½	181.0
	2⅝	65.1	11¼	285.8	10⅞	276.2	7¾	193.7
	3⅝	77.8	12¾	314.3	10⅞	276.2	8½	206.4
6	4⅝	106.4	14¼	362.0	10⅞	276.2	9¾	233.4
	0	0.0	6¾	168.3	9¼	235.0	5½	138.1
	1	25.4	9	228.6	10⅞	257.2	6½	166.7
	1½	38.1	10⅞	257.2	10⅞	276.2	7	177.8
	2	50.8	11	279.4	10⅞	276.2	7½	190.5
	2½	63.5	12¾	314.3	10⅞	276.2	8¾	208.0
	3	76.2	13½	342.9	10⅞	276.2	8¾	219.1
8	4½	104.8	15¾	384.2	10⅞	276.2	9¾	246.1
	0	0.0	8¾	219.1	10⅞	257.2	6¾	161.9
	1½	38.1	12	304.8	10⅞	276.2	8	203.2
	2	50.8	13	330.2	10⅞	276.2	8¾	217.5
	2⅝	68.3	14½	368.3	10⅞	276.2	9¾	236.5
8	3⅝	79.4	15¾	390.5	10⅞	276.2	9¾	249.2
	4⅝	106.4	17¾	441.3	10⅞	276.2	10¾	276.2

