

WT-40: Heavy Industrial/Security Framework

High-strength Spec Fence Framework

The strength and corrosion characteristics of Wheatland WT-40 fence pipe have been tested, documented and certified by independent testing agencies to ensure complete compliance with ASTM F1043, Group IC, and AASHTO M181. Wheatland WT-40 fence framework meets or exceeds the most demanding specifications and codes imposed by private, independent and government agencies.

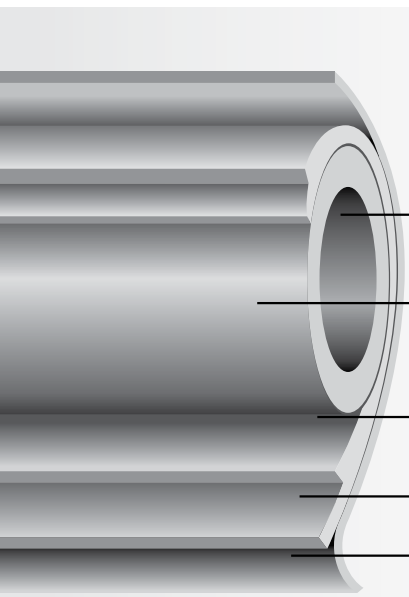

Wheatland WT-40 fence framework offers protection against corrosion and white rust.

- **90% zinc-rich interior coating**
- **Cold-rolled, high-strength steel** provides a minimum yield strength of 50,000 psi
- **Continuous 1.0 oz./ft² +/- 0.1 oz./ft² hot-dip galvanized coating**
- **Intermediate conversion coating** inhibits white rust
- **Clear polymer coating** seals in protection, and provides a smooth, lustrous finish

Materials

- 1. Steel** — Steel strip used in the manufacture of Wheatland WT-40 fence pipe shall conform to ASTM A1011 and will meet or exceed all performance criteria set forth in this standard specification.
- 2. Zinc** — Zinc used in Wheatland WT-40 fence pipe shall conform to ASTM B6. Galvanizing shall be continuous hot-dipped on OD.
- 3. Conversion Coating** — An intermediate conversion coating shall be applied in-line over the continuous hot-dip galvanizing coating to inhibit white rust and enhance corrosion resistance.
- 4. Clear Polymer Coating** — A clear polymer coating shall be applied over the intermediate conversion coating. This polymer coating provides a smooth, lustrous protective finish.
- 5. Heat-set Internal Coating** — A heat-set zinc-rich ID coating shall have a minimum zinc loading of 90%.

Weight of Coatings

- 1. Zinc** — Weight of zinc shall be 1.0 oz./ft.² +/- 0.1 oz./ft.² and shall be determined by the method described in ASTM A90.
- 2. Intermediate Coating** — Intermediate conversion coatings shall be 30 micrograms/in.² +/- 10 micrograms/in.² and shall be determined by a strip and weigh method utilizing an atomic absorption spectrophotometer or X-ray fluorescence spectrograph.
- 3. Polymer Coating** — Thickness of the clear polymer coating shall be .5 mils +/- 0.2 mils and shall be determined by measurement with a suitable magnetic or eddy current coating thickness tester.

Strength Characteristics

- 1. Load Strength** — The strength of line, end, corner and pull posts shall be determined by the use of 4' or 6' cantilevered bend test. The top rail shall be determined by a 10' free-supported beam test.
- 2. Bending Moment** — Pipe strength may be determined via the alternative method of calculating bending moment. (See table.) Conformance can be demonstrated by measuring the yield strength multiplied by the section modulus. The yield strength shall be determined according to the methods described in ASTM E8. For materials under this specification, the 0.2 offset method shall be used in determining yield strength.

Corrosion Resistance

1. Salt Spray

- a. *Exterior Surface*— The exterior clear polymer coating shall have a demonstrated ability to resist 1,000 hours or more of exposure to salt fog with a maximum of 5% red rust. Tests shall be conducted in accordance with ASTM B117.
- b. *Interior Surface*— The interior zinc-rich surface coating shall withstand no less than 650 hours of exposure to salt fog with a maximum of 5% red rust. Tests shall be conducted in accordance with ASTM B117.

2. Humidity— The exterior clear polymer coating of Wheatland WT-40 fence pipe shall resist 500 hours of exposure to 100% relative humidity without signs of blistering or peeling. Tests shall be performed in accordance with ASTM D4585 (D2247).

3. Weatherometer— The clear polymer coating of Wheatland WT-40 fence pipe shall resist failure for no less than 500 hours at a black panel temperature of no less than 145° F. Tests shall be performed in accordance with ASTM G155 Xenon Type BH apparatus (formerly G26) or ASTM G153 Carbon ArcType HH apparatus (formerly G23).

Specifying Agencies

- American Association of State Highway and Transportation Officials (AASHTO) M181, Grade 2
- Federal specifications RR-F-191/2E and RR-F-191/3E
- U.S. Army Corps of Engineers UFGS-32 31 13
- Department of the Navy
- Federal Highway Administration
- Federal Aviation Administration AC 150/5370-10 Item 162
- U.S. Department of Justice— Federal Bureau of Prisons
- ASTM Specification F1043 Group IC Standard Specification for Strength and Protective Coatings on Steel Industrial Chain Link Fence Framework
- American Institute of Architects (AIA) MasterSpec®

Availability

Wheatland Tube is committed to a full complement of finished inventory. Our high-speed material-handling capabilities enable us to react to special length requests with exceptional order fill rates.

WT-40 DIMENSIONS AND STRENGTH CHARACTERISTICS

FENCE INDUSTRY	DECIMAL OD EQUIVALENT		PIPE WALL THICKNESS		WEIGHT		SECTION MODULUS		X	MIN. YIELD STRENGTH		=	MAX. BENDING MOMENT	CALCULATED LOAD (LBS.)		
	OD	in.	(mm)	in.	(mm)	lb./ft.	(kg/m)	in. ³		(mm ³)	psi		(MPa)	lb./in.	10' Free Supported	Cantilever
														4'	6'	
1½"	1.660	42.16	0.111	2.82	1.84	2.74	0.1962	4.98	x	50000	345	=	9810	327	204	136
1¾"	1.900	48.26	0.120	3.05	2.28	3.39	0.2810	7.14	x	50000	345	=	14050	468	293	195
2¾"	2.375	60.33	0.130	3.30	3.12	4.64	0.4881	12.40	x	50000	345	=	24405	814	508	339
2½"	2.875	73.03	0.160	4.06	4.64	6.91	0.8778	22.30	x	50000	345	=	43890	1463	914	610
3½"	3.500	88.90	0.160	4.06	5.71	8.50	1.3408	34.06	x	50000	345	=	67042	2235	1397	931
4"	4.000	101.60	0.160	4.06	6.56	9.76	1.7820	45.26	x	50000	345	=	89098	2970	1856	1237

6¾" and 8¾" full-weight Schedule 40 per ASTM F1083 is available for terminal post applications. Specifications, illustrated material and descriptions are accurate as known at time of publication and are subject to change without notice.

SUBMITTAL INFORMATION

PROJECT:

CONTRACTOR:

DATE:

ENGINEER:

SPECIFICATION REFERENCE:

SYSTEM TYPE:

LOCATIONS:

COMMENTS:



4435 S. Western Boulevard
Chicago, IL 60609
P 800.257.8182
F 724.346.7260

info@wheatland.com
wheatland.com
Follow us on Twitter:
@WheatlandTube



Wheatland Tube
A ZEKELMAN COMPANY