

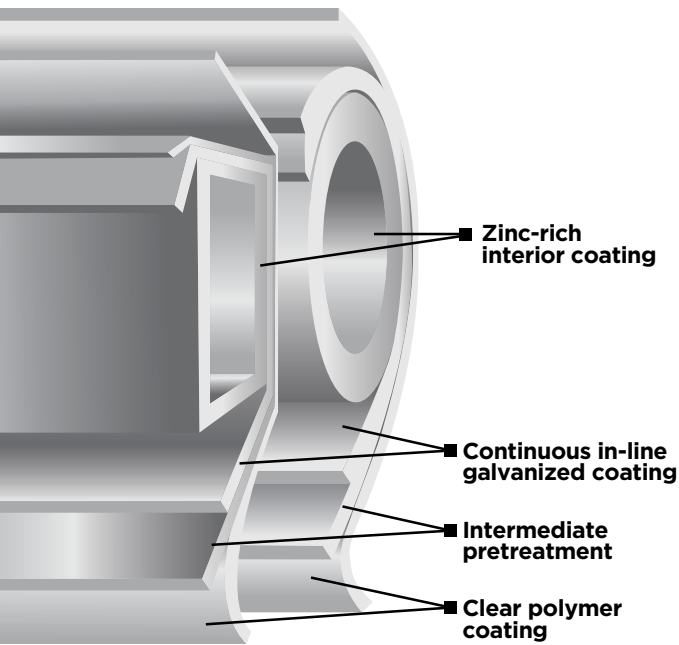

In-line Galvanized Fence Framework

Superior Quality. Superior Corrosion Protection. Superior Appearance.

Wheatland Tube's in-line galvanizing process offers superior quality, as well as corrosion and weld seam protection, when compared to the competition's products made from pre-galvanized coil. In-line galvanization produces a bright, virtually lead-free coating that is manufactured to last.



Triple-layer Protection

Our triple-coat process starts with a high-grade 99.99% pure zinc coating. An intermediate pretreatment is then applied to reduce white rust, followed by a polymer top coat that seals the surface and provides a synergistic effect to the corrosion protection well beyond the zinc coating alone. This process protects the zinc that is covering the steel tube — resulting in significantly increased service life.

Our polymer third coat not only protects the underlying zinc; it also accepts most other top coats, which means your tubing comes pre-primed for additional surface coatings that you may wish to add. Whether painting or powder coating, your tube is ready to process with only minimal surface preparation.



Wheatland Tube
A DIVISION OF ZEKELMAN INDUSTRIES

The Wheatland Difference

Wheatland Tube's in-line galvanized products outperform and outlast the competition.



Corrosion and Weld Seam Protection

To eliminate any raw steel areas and the appearance of a weld repair stripe on the OD, Wheatland's fence framework is coated on the inside and outside after welding. Our tubing is free of re-metalized weld seams to ensure complete protection from all points of corrosion.

Aesthetics

Wheatland's in-line galvanizing process produces a product with a consistently bright and shiny appearance, unlike the competition's pre-galvanized products that often appear gray and weathered.

Applications

Wheatland in-line galvanized fence framework is used in industrial, commercial and residential fencing applications. We also produce square and rectangular tubing that is used in manufactured ornamental panels, posts, railings, gates and custom fencing.



Products

Our in-line galvanized products include WT-40 (ASTM F1043 Group 1C), WT-20, WT-15, residential framework, and square and rectangle shapes.

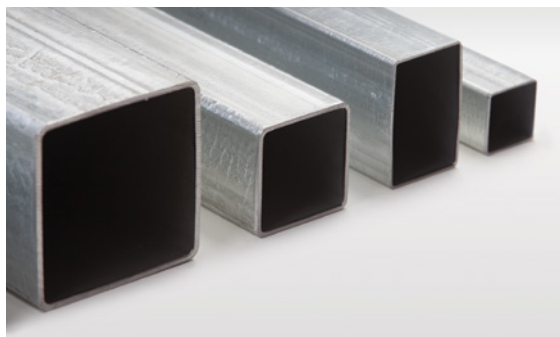

For more information about Wheatland's fence framework, visit wheatland.com/fence or call **800.257.8182**.



4435 S. Western Boulevard
Chicago, IL 60609
P 800.257.8182
F 724.346.7260

2001 East Dominguez Street
Long Beach, CA 90810
P 800.257.8182
F 724.346.7260

info@wheatland.com
wheatland.com
Follow us on Twitter:
@WheatlandTube



Wheatland Tube
A DIVISION OF ZEKELMAN INDUSTRIES